

Hydrocarbons / Total VOC FID Analyzer Model HC51M

**Air Quality
Monitoring**



Two versions:

- THC:
Total Hydrocarbons
- THC / CH₄ / nmHC:
Total Hydrocarbons,
methane and non-methane

Applications:

- Ambient air monitoring
- Monitoring around industrial sources emitting VOCs
- Continuous emissions monitoring (CEM) by dilution
- Measurement of impurities in industrial gases

Exclusive features:

- High sensitivity, stable, linear FID detector
- Temperature controlled pneumatics
- Graphic Liquid Crystal Display (LCD)
- Interactive menu driven software
- Synoptic flow diagram display
- Remote troubleshooting diagnostics
- Auto-ranging
- Automatic response time
- Real time calibration graph
- User programmable ranges and average times
- Built-in serial interface (RS232/RS422)
- Built-in storage of the last 1500 average data
- Full remote emulation of the analyzer
- Field proven technology and design

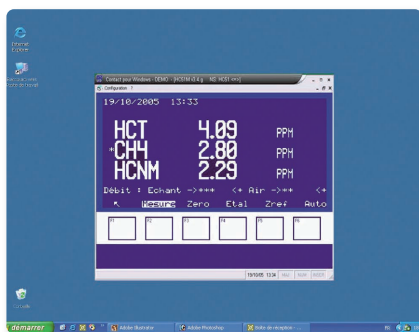

CONTACT remote control software

Hydrocarbon & Total VOC FID Analyzer - Model HC51M

Specifications:

- Programmable measurement ranges: 0-10 / 50 / 100 / 500 / 1,000 ppm, or user selectable
- Auto-ranging
- Noise: 0.025 ppm
- Lower detectable limit: 0.05 ppm
- Response time: automatic or programmable
- Zero drift: 0.1 ppm / 7 days
- Span drift: < 1 % / 7 days
- Linearity: ± 1 % full scale
- Sample flow rate: 1.4 l/min
- Built-in sampling pump
- Average data: programmable from 1 up to 9999 min
- Data storage: last 1,500 average data
- 3 configurable analog outputs: 0 - 20 mA, 4 - 20 mA, 0 - 1 V, 0 - 10 V
- Serial link: RS232 / RS 422.
- Housing: Rack 19" - 4U
- Dim. : 483 x 581 x 177 mm (W x D x H)
- Weight: 27 kg
- Power supply: 230 V, 50 / 60 Hz or 115 V, 60 Hz.
- Consumption: 450 V A.
- Operating temperature: + 10 to +35°C

Utilities:

- Hydrogen : 0.04 l/mn (2 bars)
- Combustive air: 0.5 l/mn (2.5 bars)

Options:

- Internal zero air generator (compressor excluded)
- External air compressor
- Internal converter for measurement of methane and non methane hydrocarbon
- Special version for measurement in pure oxygen



Principle of operation:

The analyzer uses the principle of flame ionization detection (FID) to measure the concentration of hydrocarbons in air.

The ionization mechanism of organic substances in the flame is carried out in two stages :

- cracking of organic compounds in the center zone of the flame and forming of CH₁[•], CH₂[•], CH₃[•] radicals.
- chemical ionization in contact with oxygen according to reaction:
CH[•] + O -> CHO⁺ + e⁻.

The analyzer's electrometer measures the current generated by the ionization of the carbon atoms in the flame fueled by a hydrogen/air mixture.

To distinguish between "total" and "non-methane" hydrocarbons, an optional selective converter oven is used to oxidize all the non-methane hydrocarbons.

The temperature controlled pneumatics prevents condensation.

The flow is automatically adjusted and the instrument is provided with automatic ignition of the flame in case of flame out or power failure.

The HC51M is delivered with built-in zero/span solenoid valves to be connected to an external source of gas. Zero/span checks can be performed manually, automatically (programmable cycles) or via remote control (dry contact, RS232). Real time calibration graphs can be displayed during span check operation. Multi-tasking software, combined with the LCD graphic display, gives the user easy and fast access to the instrument set-up, status and maintenance parameters.

Real-time synoptic, auto-diagnostic and maintenance data screens can be displayed while the instrument is operating.

The automatic response time function determines the measurement integration time best suited for the measurement of hydrocarbons concentrations.

The HC51M includes data collection and logging features and stores the average values.

The built-in RS232 interface and digital communication protocol allow full PC instrument emulation for remote control and troubleshooting as well as a common serial link, thus achieving a fully digital air pollution monitoring station.

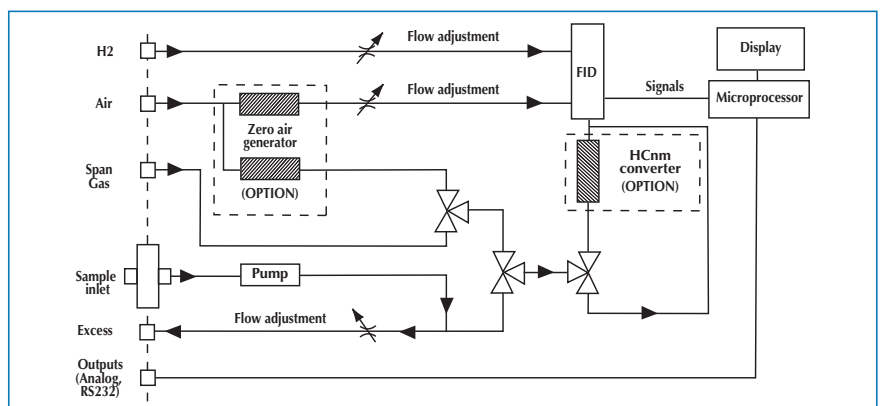

Specifications subject to modifications without prior notice - ref.: HC51M_uk - Gimnick - 0408

